

- NOTE: 1.MATERIAL SPECIFICATION:  
 1.HOUSING:HIGH TEMPERATURE RESISTANT PLASTIC,UL94 V-0.  
 2.CONTACTS:COPPER ALLOY  
 4.FRONT SHELL: STAINLESS STEEL  
 2.MECHANICAL PERFORMANCE,  
 2-1.INSERTION FORCE: 0.5~2.0kgf.  
 2-2.REMOVAL FORCE: 0.8kgf~2.0kgf.  
 2-3.DURABILITY: 10000 CYCLES.  
 3.ELECTRICAL PERFORMANCE,  
 3-1. CURRENT RATING:5/3.0A  
 VOLTAGE RATING:20V  
 3-2. LLCR:  
 VBUS & GND PINS AND OTHER PINS: 40mΩ/PIN MAX.  
 SHIELD: 50mΩ/MAX.  
 LLCR MAX. CHANGE OF ALL PINS: 10mΩ.  
 3-3.INSULATION RESISTANCE: 100MΩ MIN  
 3-4.DIELECTRIC WITHSTAND VOLTAGE,AC 100V FOR 1 MINUTE.  
 4. ENVIRONMENTAL PERFORMANCE:  
 OPERATING TEMPERATURE: -25°C~+85°C.  
 5.IR REFLOW:  
 THE PEAK TEMPERATURE ON THE BOARD SHALL  
 BE MAINTAINED FOR 10 SECONDS AT 260°C.  
 5.P/N: USBC02-116XX-X00R

USB TYPE-C PIN ASSIGNMENTS

PIN NUMBER	SIGNAL NAME	PIN NUMBER	SIGNAL NAME
A1	GND	B12	GND
A4	VBUS	B9	VBUS
A5	CC1	B8	SBU2
A6	Dp1	B7	Dn2
A7	Dn1	B6	Dp2
A8	SBU1	B5	CC2
A9	VBUS	B4	VBUS
A12	GND	B1	GND

P/N	(F) 脚长	COLOER	额定电流
HC-TYPE C-16P-CH3.18-3A-02	0.90mm	黑色	3A
HC-TYPE C-16P-CH3.18-3A-B5-02	0.90mm	B5:蓝色(2990)	3A
HC-TYPE C-16P-CH3.18-3A-Y-02	0.90mm	Y:黄色(17493)	3A

Ordering Information

HC-TYPE C - 16P - \*\* \* - \*A - F\* - \* - 02

Pin: 04P, 08P, 09P, 12P, 16P, 24P  
 Type: TM=Top Mount(板上), US=DIP+SMT(插焊/贴片), MW=Mid Mount(中板), CH=Center Height(铁壳), VS=Vertical SMT(垂直贴片), DP=DIP(插焊), CP=Clip(夹板), FL=Flag(侧插)  
 G=带盖, Y=带壳, S=双壳, SM=双外壳, +带弹, 全金属壳, D=带弹片  
 Current Rated: 3A, 5A, 10A  
 \*Foot Length: 0.90, 1.25, 1.50, 2.00, 2.50, 3.00, 3.50, 4.00, 4.50, 5.00, 5.50, 6.00, 6.50, 7.00, 7.50, 8.00, 8.50, 9.00, 9.50, 10.00, 10.50, 11.00, 11.50, 12.00, 12.50, 13.00, 13.50, 14.00, 14.50, 15.00, 15.50, 16.00, 16.50, 17.00, 17.50, 18.00, 18.50, 19.00, 19.50, 20.00, 20.50, 21.00, 21.50, 22.00, 22.50, 23.00, 23.50, 24.00, 24.50, 25.00, 25.50, 26.00, 26.50, 27.00, 27.50, 28.00, 28.50, 29.00, 29.50, 30.00, 30.50, 31.00, 31.50, 32.00, 32.50, 33.00, 33.50, 34.00, 34.50, 35.00, 35.50, 36.00, 36.50, 37.00, 37.50, 38.00, 38.50, 39.00, 39.50, 40.00, 40.50, 41.00, 41.50, 42.00, 42.50, 43.00, 43.50, 44.00, 44.50, 45.00, 45.50, 46.00, 46.50, 47.00, 47.50, 48.00, 48.50, 49.00, 49.50, 50.00  
 Colour: 默认:Black, W=White, B5=Blue(2995C), G=Green, O=Orange, P=Purple, Y=Yellow

GENERAL TOLERANCE		制图
DIM	TOL	DRAWING
X.X	±0.30	审核
X.XX	±0.20	批准
X.XXX	±0.10	APPROVAL
Angle	±3.0°	比例
		SCALE
		投影
		Projection

**深圳市华灿天禄电子有限公司**  
 ShenzhenhuacantianluELECTRONICS CO.,LTD

产品名称	TYPE CF 16P 垫高1.6	版本	A
TITLE	CH=3.18mm 脚长0.9 带弹 带柱	REV.	
产品料号	HC-TYPE C-16P-CH3.18-XA-X-02	单位	mm
PART NO.		UNITS	
材料		页次	1/2
MATERIAL		SHEET	

pcs/box	boxs/Carton	Pcs/Box
600	10	6000

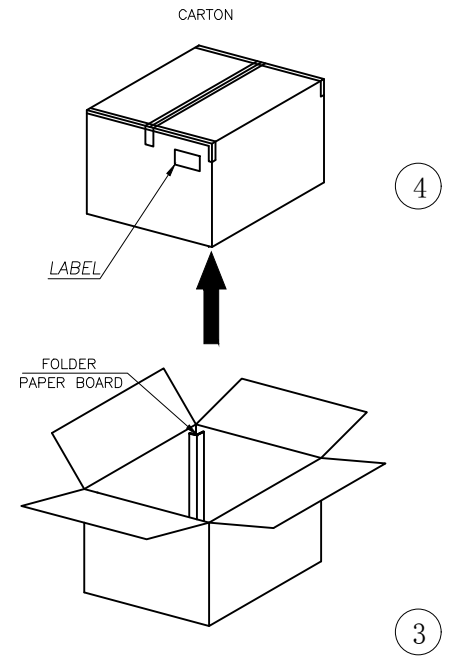
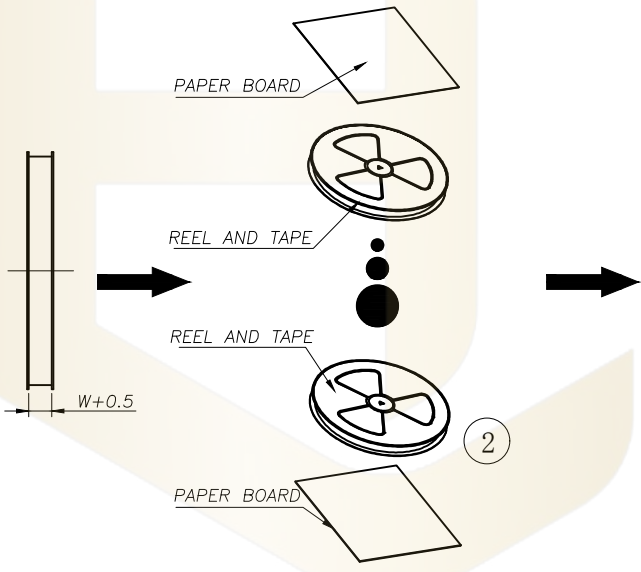
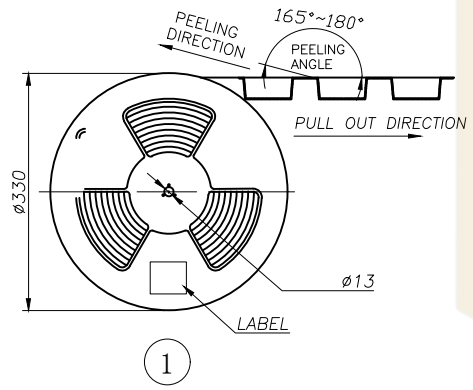
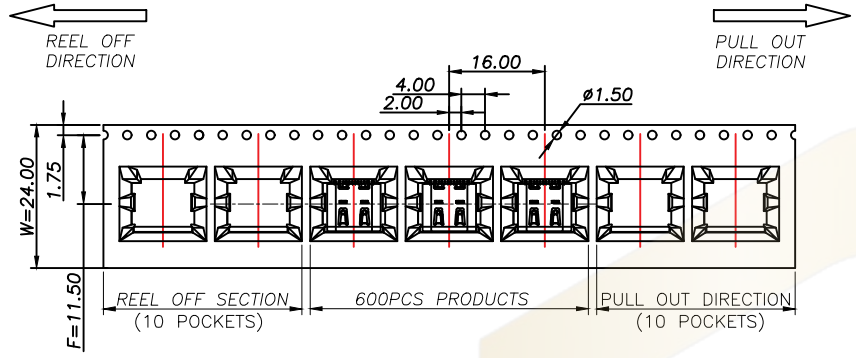

			GENERL TOLERANCE		制图	深圳市华灿天禄电子有限公司			
			DIM	TOL	DRAWING	ShenzhenhuacantianluELECTRONICS CO., LTD			
			X.X	$\pm 0.30$	审核	产品名称	TYPE CF 16P 垫高1.6	版本	A
			X.XX	$\pm 0.20$	CHECK	TITLE	CH=3.18mm 脚长0.9 带弹 带柱-包装图	REV.	
			X.XXX	$\pm 0.10$	批准	产品料号	HC-TYPE C-16P-CH3.18-XA-X-02	单位	mm
1	初版发行	日期	Angle	$\pm 3.0^{\circ}$	APPROVAL	PART NO.		页次	2/2
序号	变更内容	日期			SCALE	MATERIAL		SHEET	
No.	MODIFY CONTENT	MODIFY DATE			投影				